

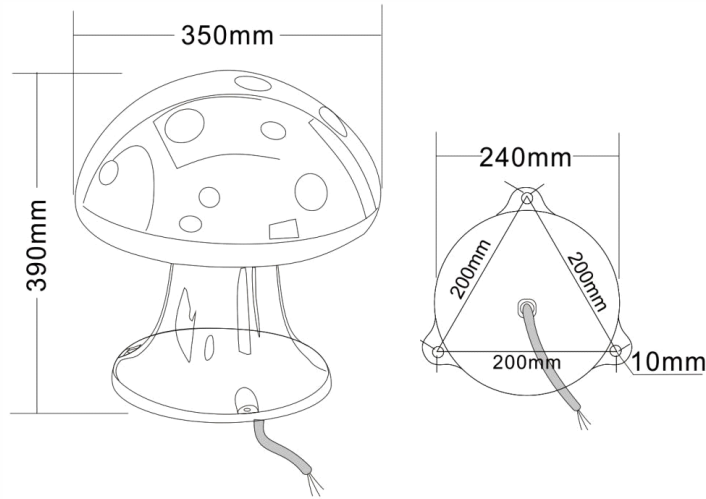

Landscape Garden Speaker

T-500H



Note: Due to the continuous product updating, the color and dimension of the products are subject to the actual product. The following specification are for reference only.

Specifications:

Model	T-500H
Power Taps @100V	12.5W, 25W
Power Taps @70V	6.5W, 12.5W
SPL(1W/1M)	95dB
Frequency Response (-10dB)	80Hz -20KHz
Finish	Organic resin
Speaker Driver	2×4"+2.5"
IP Rate	IP66
Cutout Size	200 x 200 x 200mm
Dimensions(mm)	H: 390
Weight	5.49Kg
Impedance	Black:COM,White:800Ω,Green:400Ω