

## T-701H Outdoor Column Loudspeaker (20W)

### Features

- Built-in 100v/70v transformer
- Weatherproof column type loudspeaker
- IP6 waterproof level
- 3.5" x 2 full range driver
- Power taps at 20W @100V
- Aluminum enclosure & grille in white
- A pair of metal mounting brackets are supplied

### Description

The T-701H is a weatherproof outdoor column speaker built-in 70v/100v transformer. The 70v/100v transformer technique reduces line losses on longer distance and allows easy parallel connection of multiple loudspeakers.



The built-in 2 units 3.5" full range speaker drivers are designed of wide frequency response 90-20kHz, the multiple power taps of 20W could meet different applications varies from room size and ambient noise surroundings.

The aluminum enclosure and grille are of white color. It is also designed of weatherproof and heavy damage proof finish. Easy and secure wall mount installation in outdoor area through the supplied pair of metal mounting brackets.

It is ideal choice for industrial and commercial applications in the outdoor area of train station, shopping mall, parking area and factory where background music and paging is needed.

### Specification

| Model              | T-701H                 |
|--------------------|------------------------|
| Power Taps @100V   | 20W                    |
| Power Taps @70V    | 10W                    |
| ISPL               | 90dB±3dB               |
| Impedance          | Black: COM White: 500Ω |
| Frequency Response | 90-20KHz               |
| Finish             | Body: Aluminum white   |
| IP Rate            | IPx6                   |
| Dimension          | 105 x 98 x 280mm       |
| Speaker Driver     | 2 x 3.5"               |
| Weight             | 2.2Kg                  |

Appearance:

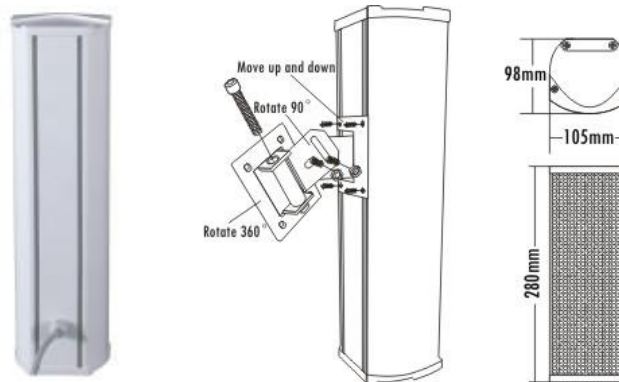

Direction Diagram:

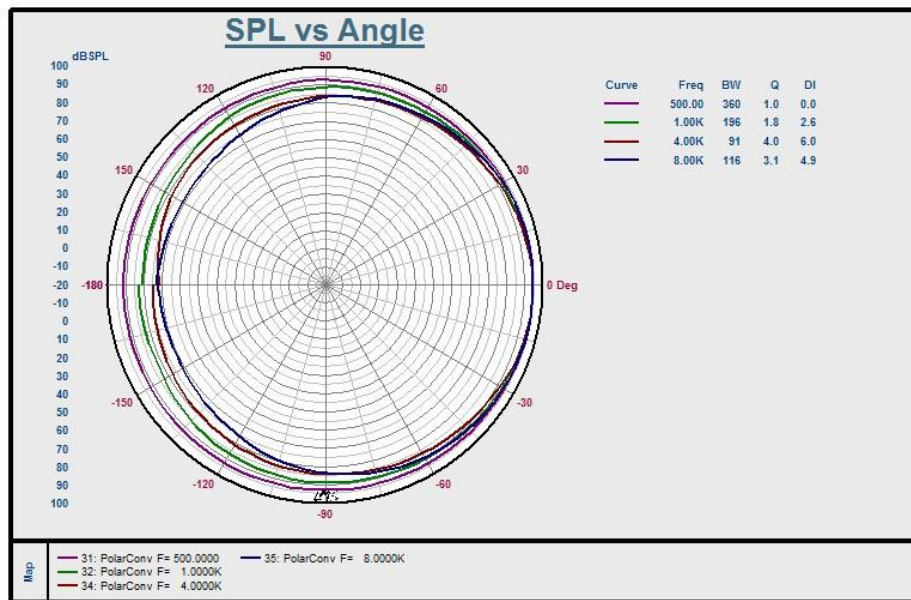

Frequency Response:

